

CHANNEL BACKER®

The **C. D. Sparling Channel Backer®** is specifically engineered to be used on 1/2" and 5/8" drywall. Presently available in two models, the CB-6-GB is manufactured from 18 gauge (.049), type 304, stainless steel and high-density polyethylene. The CB-4-GB is manufactured with a polypropylene channel backer and stainless steel mounting hardware. Load results exceed the ASTM F446-85 standard, which requires grab bars that are installed horizontally withstand an applied load of 250 pounds. See chart for recommended applications and load results.

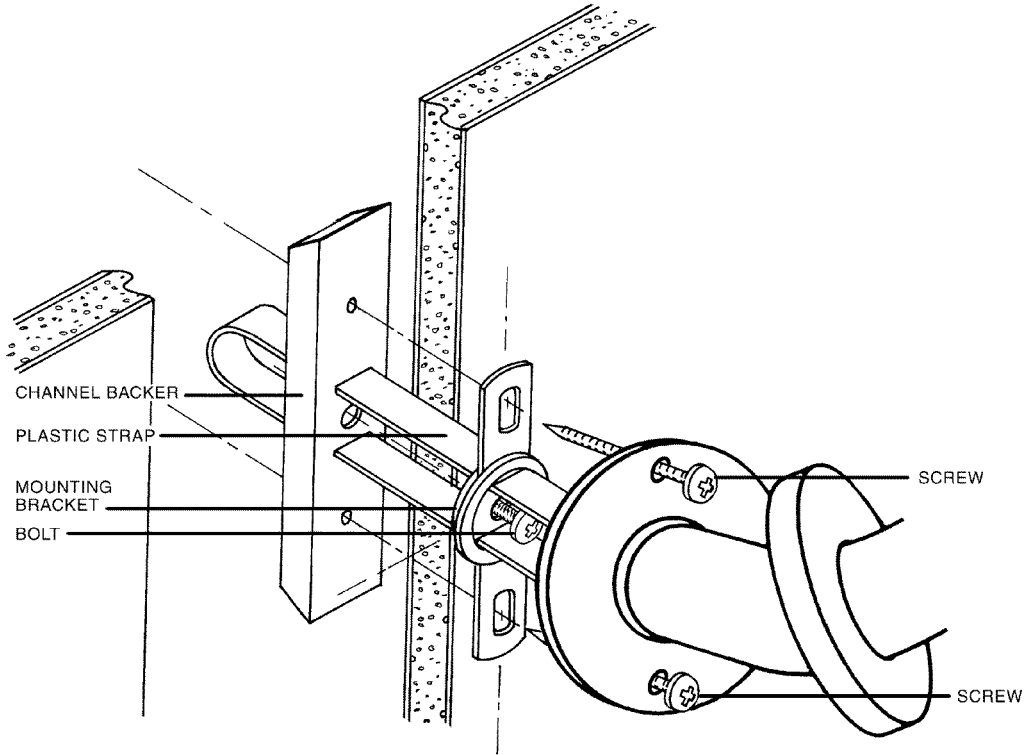

MODELS	FLANGE HOLE CENTERS	DRYWALL/WALL THICKNESS	LOAD RESULTS**
CB-6-GB	2" THRU 2 1/2" *	1/2" (not greater)	420 LBS
CB-4-GB	2" THRU 2 1/2" *	5/8" and 3/4"	520 LBS

* For 1 1/2" thru 2" mounting centers ask for "B" type mounting bracket. "B" type to be used with our "GL Series) grab bars.

** NAHB Research Center test results available upon request.

WARNING: Do not install "Channel Backer" into wet or deteriorating drywall. Channel Backer is not to be used on fiberglass tubs or acrylic walls.

C.D. Sparling Company
 498 Farmer Street
 Plymouth, Michigan 48170
 Phone (734) 455-3121 • Fax (734) 455-7322
www.cdsparring.com